

**HQ-150
COMMUNICATIONS
RECEIVER**

**TECHNICAL
DESCRIPTION
AND
OPERATING
INSTRUCTIONS**

HAMMARLUND

Hammarlund Manufacturing Company
A Giannini Scientific Co.
53 West 23rd Street, New York 10, N. Y.
Export Department: 13 East 40th Street, New York 16, N. Y.



Figure 1. The HQ-150 Receiver

TUBE COMPLEMENT

Symbol	Type	Tube	Function
V1	6C4	Triode	Oscillator
V2	6BA6	Remote Cutoff Pentode	RF Amplifier
V3	6BE6	Pentagrid Converter	Mixer
V4	6BA6	Remote Cutoff Pentode	1st IF Amplifier
V5	6BA6	Remote Cutoff Pentode	2nd IF Amplifier
V6	6BA6	Remote Cutoff Pentode	3rd IF Amplifier
V7	6AL5	Twin Diode	Detector, AVC; Noise Limiter
V8	12AX7	Twin Triode	1st AF Amplifier; BFO
V9	6V6GT/G	Beam Power	Audio Power Output
V10	0C3/VR105	Voltage Regulator	Voltage Regulator
V11	5U4GB	Full Wave Rectifier	Rectifier
V12	12AX7	Twin Triode	Q Multiplier
V13	6BZ6	Pentode	Crystal Calibrator



INTRODUCTION

The Hammarlund HQ-150 is an advanced design, general purpose, superheterodyne communications receiver designed to maintain high performance characteristics for many years without adjustment. The receiver has a self-contained stabilized power supply operating from a 50-50 cps, 105-125 volt AC source.

Frequency coverage is continuously tunable from 540 KCS to 31 KCS (555 to 9.7 meters) with extremely fine control of selectivity to separate crowded signals. Full use of the receiver's high sensitivity is available for reception of even the weakest stations because of inherently high signal-to-noise ratio and the superior Hammarlund noise limiter. The special patented Hammarlund crystal filter provides optimum selectivity for the high attenuation of closely adjacent interfering signals.

In addition a Q Multiplier is provided for either the accentuation of any desired signal, or the attenuation of any undesired signal, within the pass band of the receiver IF amplifier.

Band spread tuning is available on the four higher frequency ranges, with direct calibration for the 80, 40, 20, 15, and 10 meter amateur bands. Calibration charts for other ranges may be easily made for use with the arbitrary band-spread logging scale.

The receiver is equipped with a Crystal Calibrator which generates 100 KC markers or signals at 100 KC intervals within the frequency range of the receiver.

While this receiver was designed primarily for communications use, good fidelity of music and voice reproduction in both the standard and shortwave broadcast bands is provided. Power ripple is negligible. Either headphones or loudspeaker may be used, with automatic volume control, keeping music and voice reception at a constant level.

The HQ-150 receiver is equipped with an unusually stable beat frequency oscillator which allows you, the operator, a range of audio tones when receiving telegraph or code signals, or excellent single side-band reception when that mode of transmission is being used.

An "S" Meter enables you to obtain accurate reports on received phone signals while the Send-Receive switch and relay connections permit associated transmitter operation without interference.

Large, comfortable and carefully positioned controls make the HQ-150 a truly professional-type receiver, the ideal instrument for operating in extremely crowded shortwave bands.

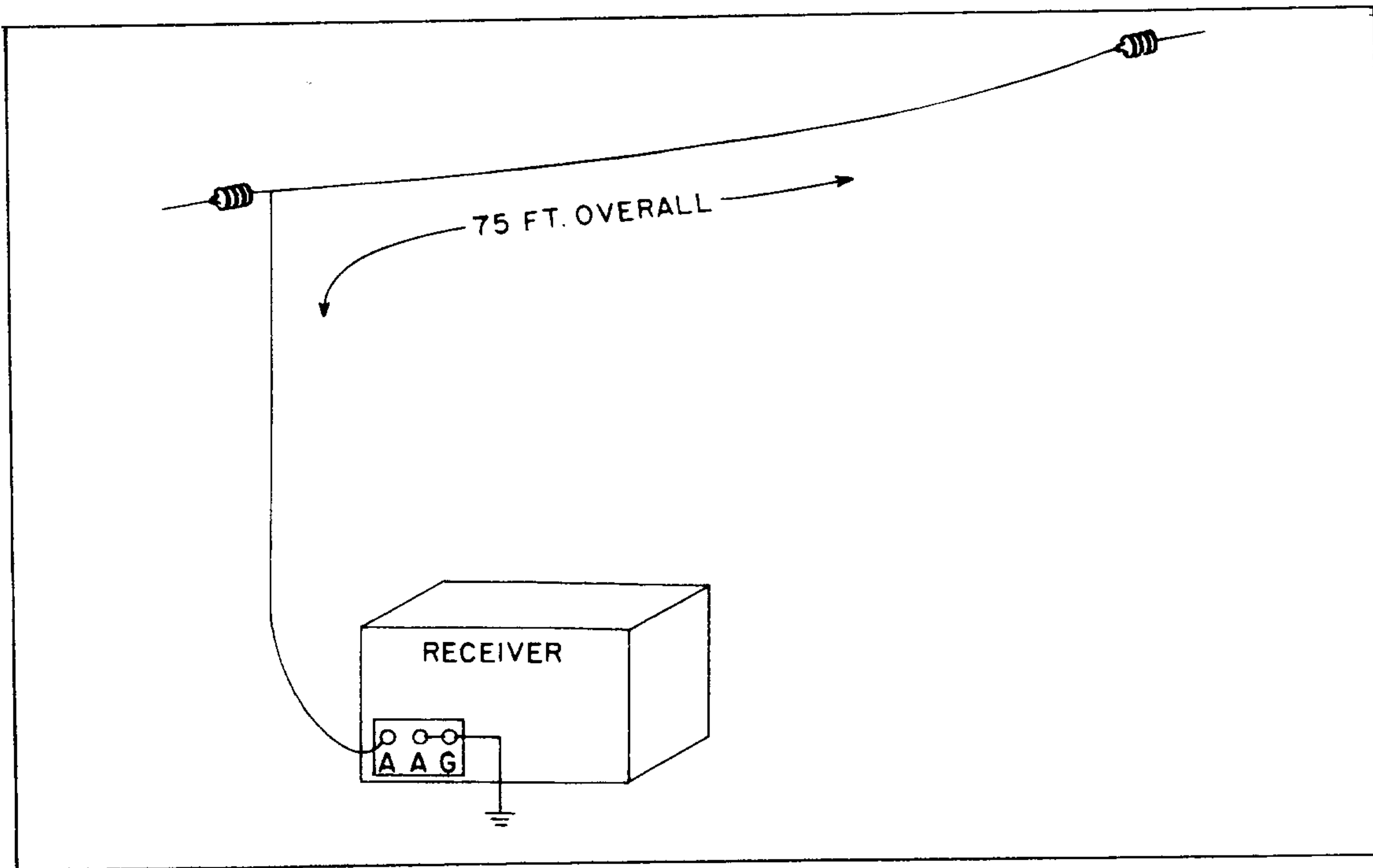

Figure 2. Installation of Single-wire Antenna

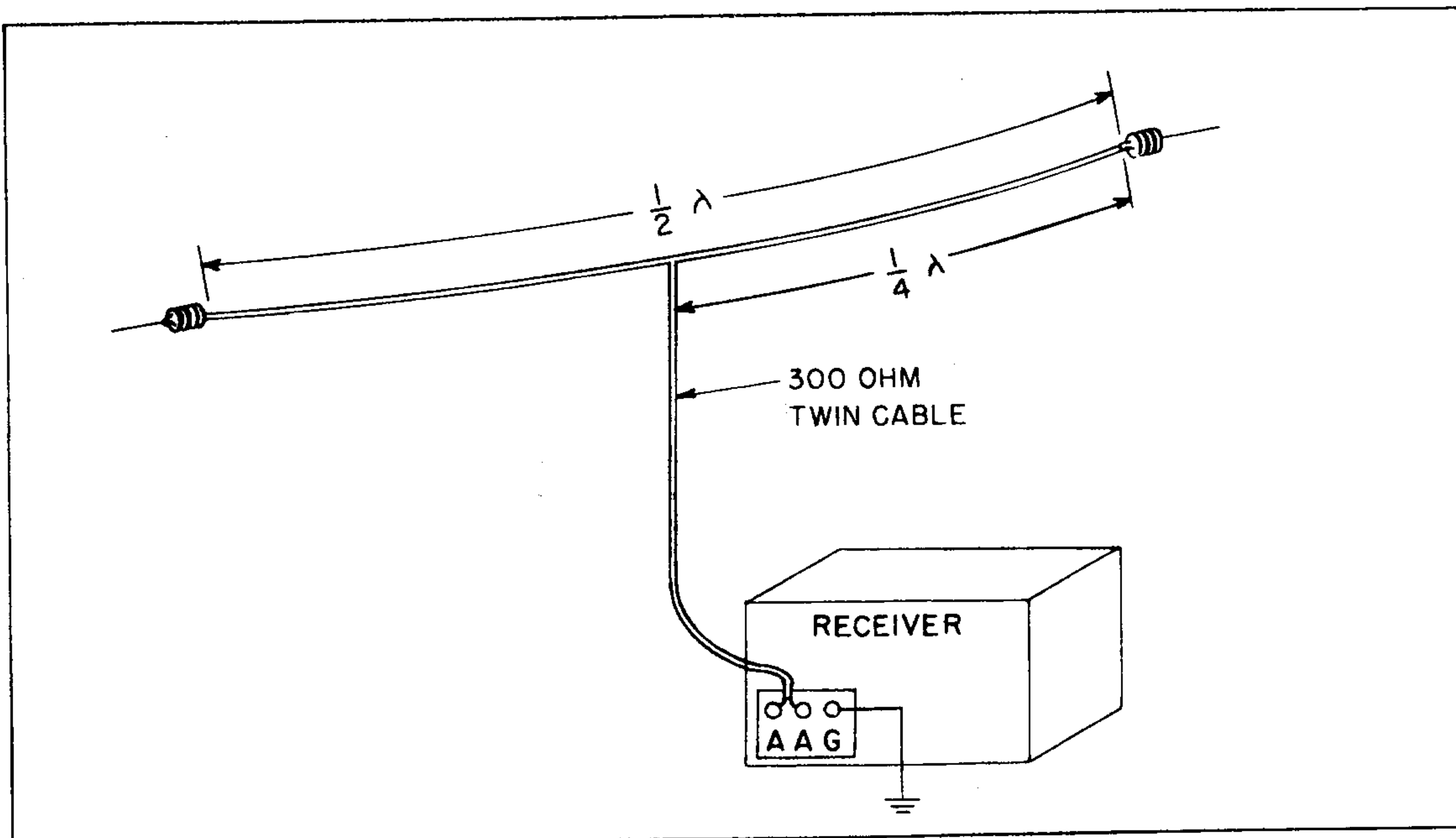

Figure 3. Installation of Folded Dipole Antenna



INSTALLATION

UNPACKING

Unpack the receiver carefully. Make sure that the fuse, tubes, associated tube shields and pilot lamps are in place. Tubes V4, V5, V6, V8, V9, V10 and V11 are not shielded.

CONNECTING RECEIVER

Connect the 6 to 8 ohm permanent magnet dynamic speaker to the two terminals marked SPEAKER on the rear of the receiver chassis (Figure 4). For best performance do not place speaker on top of receiver cabinet. The antenna may then be connected as described under ANTENNA.

INSTALLING ANTENNA

The HQ-150 is designed to work efficiently with a single wire or balanced type of antenna. A good match to most antenna systems of 50 to 300 ohms impedance will be obtained, by use of the antenna trimmer control (Index 7, Figure 5) which is located on the front panel.

For general coverage an indoor antenna of 20 to 50 feet will give surprisingly good reception. A long single wire outdoor antenna such as shown in Figure 2 will generally give entirely satisfactory performance. This wire may be 50 to 75 feet long.

For best reception the antenna should be isolated as much as possible from neighboring objects.

Optimum performance on a particular amateur band or other narrow tuning range will be obtained by using a half-wave dipole or folded dipole fed with 300 ohms or suitable leadin as shown in Figure 3.

The length of the required 1/2 wave-length dipole may be calculated by the following formula:

$$\text{Length (feet)} = \frac{468}{\text{Freq. (MCS)}}$$

Each half, or 1/4 wave length, is 1/2 the above length.

A good ground, although not absolutely necessary, will frequently aid in reception and reduce stray line hum.

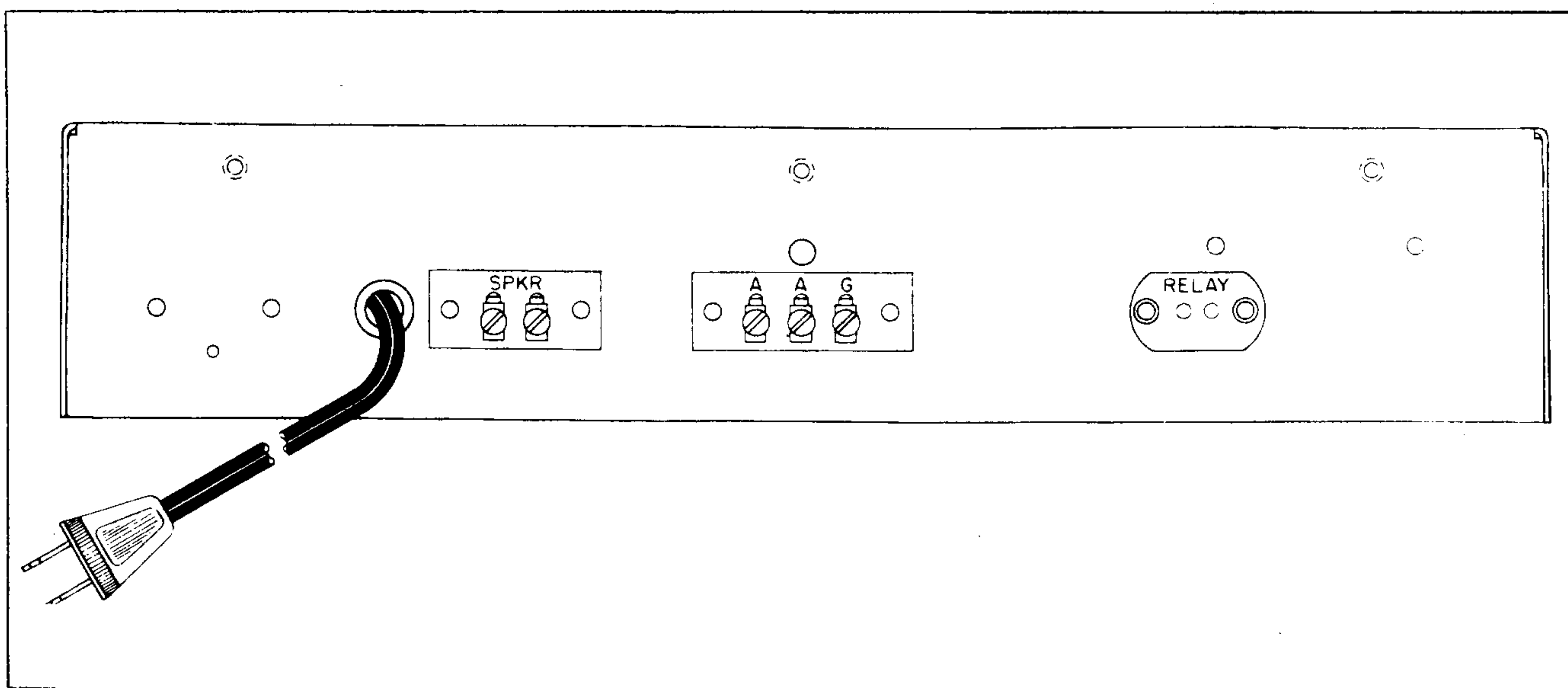
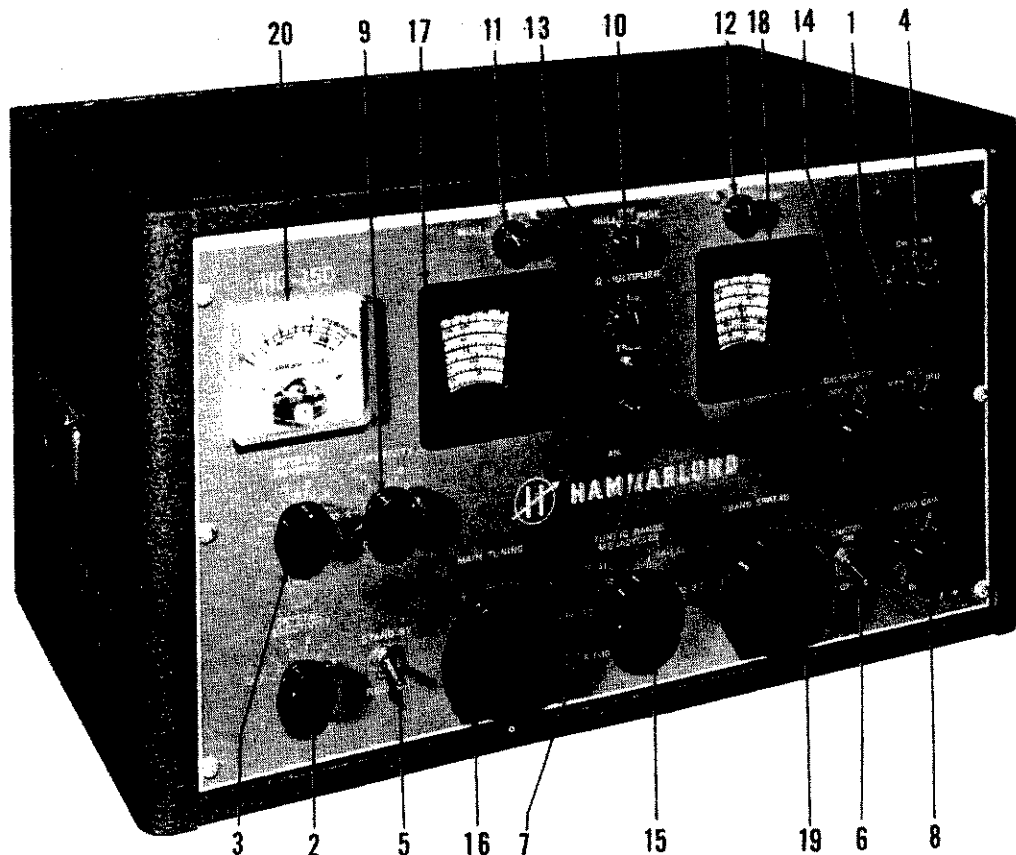

Figure 4. Connection Points at Rear of Chassis



INDEX NO.		Setting for PHONE	Setting for CW (Code)	Setting for SSB
1	MAN-AVC-BFO	AVC	BFO	BFO
2	CRYSTAL SELECTIVITY	As Required	As Required	As Required
3	CRYSTAL PHASING	At Arrow	At Arrow	At Arrow
4	CW TONE	Inoperative	±2	±2
5	STANDBY-RECEIVE	RECEIVE	RECEIVE	RECEIVE
6	LIMITER	As Required	As Required	As Required
7	ANTENNA	To Peak Signal	To Peak Signal	To Peak Signal
8	AUDIO GAIN	Adjust	10	10
9	SENSITIVITY	10	Adjust	Adjust
10	Q MULTIPLIER	OFF	OFF	OFF
11	NULL	As Required	As Required	As Required
12	PEAK	As Required	As Required	As Required
13	FREQ	As Required	As Required	As Required
14	CALIBRATOR	OFF	OFF	OFF
15	BAND SWITCH	As Required	As Required	As Required
16	MAIN TUNING CONTROL	As Required	As Required	As Required
17	MAIN TUNING DIAL	As Required	As Required	As Required
18	BAND SPREAD TUNING DIAL	As Required	As Required	As Required
19	BANDSPREAD TUNING CONTROL	As Required	As Required	As Required
20	"S" METER (CARRIER LEVEL)	For Maximum Deflection	Inoperative	Inoperative

Figure 5. Location of Controls



OPERATION

Basically, all that is necessary to operate a radio receiver are the tuning and volume controls. The additional knobs and switches found on a professional-type receiver such as the HQ-150 control functions which greatly improve operating performance.

NORMAL CONTROL SETTINGS

For initial operation, set the controls as indicated on Figure 5.

The receiver ON-OFF switch is on the AUDIO GAIN control. If you are unfamiliar with the type of power available, check with the local power company before plugging in receiver. Turn on the receiver by advancing the AUDIO GAIN. Check to see that the pilot lamps light and tubes warm up.

While the tubes are heating, set the TUNING RANGE switch in the .54-1.32 position, MAN-AVC-BFO on AVC (automatic volume control), CRYSTAL SELECTIVITY on OFF, STANDBY-RECEIVE on RECEIVE, and SENSITIVITY on "10". Tune in the broadcast stations by using the MAIN TUNING dial and AUDIO GAIN control.

Should accentuation of a particular signal in the IF pass band be desired set the following controls:

- Q MULTIPLIERPlace in the PEAK position.
- FREQRotate control until some gain is noted in the desired signal.
- PEAKAdjust for maximum gain of desired signal.

Should attenuation of a particular signal in the IF pass band be desired, set the following controls:

- Q MULTIPLIERPlace in the NULL position.
- FREQRotate control until a decrease in gain is noted in the undesired signal.
- NULLAdjust for maximum attenuation of undesired signal.

To cause the Q MULTIPLIER to be inoperative, place the Q MULTIPLIER switch in the OFF position.

TUNING PROCEDURE

For accurate tuning watch the "S" meter. Always adjust the tuning control for maximum meter reading for the station to which you are listening.

To tune in a standard broadcast station, it is merely necessary to tune the MAIN TUNING dial to the desired frequency. The BAND SPREAD dial is inoperative on the first two ranges.

For reception of short-wave stations with the MAIN TUNING dial only, it is necessary to set the BAND SPREAD dial to 100 in order to attain correct calibration of the MAIN TUNING dial scale.

The BAND SPREAD dial is calibrated directly for the 80, 40, 20, 15, and 10 meter amateur bands. To make use of this feature, set the BAND SPREAD dial to the high frequency end of the desired amateur band, turn the MAN-AVC-BFO switch to BFO, set the CW TONE control to zero, switch the calibrator on and tune the MAIN DIAL for zero beat at the upper frequency end of the desired band. If the BAND SPREAD calibration is a fraction of a division off at or near a portion of the band where operation is desired, check the nearest 100 KC division by counting down from the high frequency end of the band, set the BAND SPREAD dial at this 100 KC division and retune slightly with the MAIN TUNING dial for zero beat. If the BAND SPREAD dial reads low, the main dial will tune toward a lower frequency to make this correction and vice versa. Observing this will prevent setting the main dial to an erroneous 100 KC point. The BAND SPREAD dial then may be tuned over the range selected.

A 0-100 arbitrary logging scale is also provided for band-spread tuning of any desired ranges which are not directly calibrated. Again the MAIN TUNING dial is set at the high end of the selected range. Tuning the BAND SPREAD dial from 100 to 0 tunes the receiver progressively lower in frequency.

The table on the following page indicates the approximate frequency range covered by the BAND SPREAD dial at various settings of the MAIN TUNING dial for each of the four higher frequency bands of the receiver.

The ANTENNA compensator knob, the final adjustment, also should be set for greatest "S" meter deflection.

When automatic volume control is not desired, the MAN-AVC-BFO switch can be set on MAN (Manual), the AUDIO GAIN control turned fully clockwise, and the SENSITIVITY control employed to provide the desired



Band	Low End	Middle	High End
3.2 - 5.7 MCS	0.4 MC	0.7 MC	1.25 MCS
5.7 - 10 MCS	0.2 MC	0.5 MC	0.9 MC
10 - 18 MCS	0.2 MC	0.5 MC	0.9 MC
18 - 31 MCS	0.6 MC	1.2 MCS	2.2 MCS

The following is an example of the use of the above table.

Main Tuning Dial Setting	Band Spread Dial Rotated 100 to 0 Will Cover	Band Switch Range
Low end of range	400 KCS or .4 MC	3.2 - 5.7 MCS
Middle of range	700 KCS or .7 MC	3.2 - 5.7 MCS
High end of range	1,250 KCS or 1.25 MCS	3.2 - 5.7 MCS

volume. When headphones are plugged into the jack in the lower right-hand corner of the panel, the speaker is disconnected. On the rear of the chassis are two pin-jacks marked RELAY which can be connected to the send-receive relay of the transmitter for break-in operation. With the STANDBY-RECEIVE switch in STANDBY, the receiver is silent but ready for instant use.

The PHASING control normally is set at the arrow in the center of its scale, but may be adjusted to cut out interference from stations on either side of the signal. With the CRYSTAL SELECTIVITY switch the operator can choose the degree of selectivity that provides the greatest fidelity with minimum interference. The first three positions are for phone reception and the fifth and sixth for single signal code reception in extremely crowded bands.

SINGLE SIDE-BAND (SSB) OPERATION

The BFO (Beat Frequency Oscillator) provides a wide choice of tones for CW code operation and carrier

reinsertion for single side-band reception (SSB). Turning the MAN-AVC-BFO switch to BFO disconnects the automatic volume control, and the SENSITIVITY control must then be employed. When using the receiver for single side-band reception the following procedure should be observed:

1. Set the CW TONE control to 2 on either side of zero.
2. Using the BAND SPREAD control, first zero beat the desired SSB (single side-band) signal, then tune for maximum intelligibility.
3. Should the signal still not be intelligible, rotate the CW TONE control to 2 on the other side of zero.
4. Carefully adjust the BAND SPREAD control for greatest clarity.

It is often a great help to use the LIMITER in short-wave reception.

TUNING RANGES

Band	Frequency	Meters Wave Length
1	.540 - 1.32 MCS	555 - 227
2	1.32 - 3.2 MCS	227 - 93.7
3	3.2 - 5.7 MCS	93.7 - 52.6
4	5.7 - 10 MCS	52.6 - 30.0
5	10 - 18 MCS	30.0 - 16.7
6	18 - 31 MCS	16.7 - 9.7



CIRCUITRY

PRESELECTION

The antenna input coupling and RF amplifier stage provide the necessary preselection and gain for high performance and rejection of undesired signals. The high signal level at the mixer grid, V3, contributes to a favorable signal to noise ratio.

Both grid and plate circuits of the RF stage are tuned; individual tuning coils are selected for each band.

The antenna compensating capacitor, adjustable from the front panel, permits the receiver to be resonated for optimum performance with the antenna in use.

CONVERTER STAGE

A high degree of oscillator stability is attained by the

use of a separate mixer (6BE6), V3, and an independent oscillator (6C4), V1.

The output signal from RF amplifier, V2, is heterodyned with the output of the local high frequency oscillator, V1, and electronically combined within the mixer tube, V3. On the four lower frequency ranges the local oscillator is 455 KCS above the signal frequency. On the two highest ranges the oscillator is 455 KCS below the signal frequency.

Low-loss tube sockets, ceramic band switches, temperature compensating capacitors, zero temperature coefficient ceramic trimmers, and a bi-metallic compensating plate all contribute to oscillator stability. Additional frequency stability is attained by applying regulated voltage to the oscillator plate and by the rugged construction of the entire oscillator section assembly.

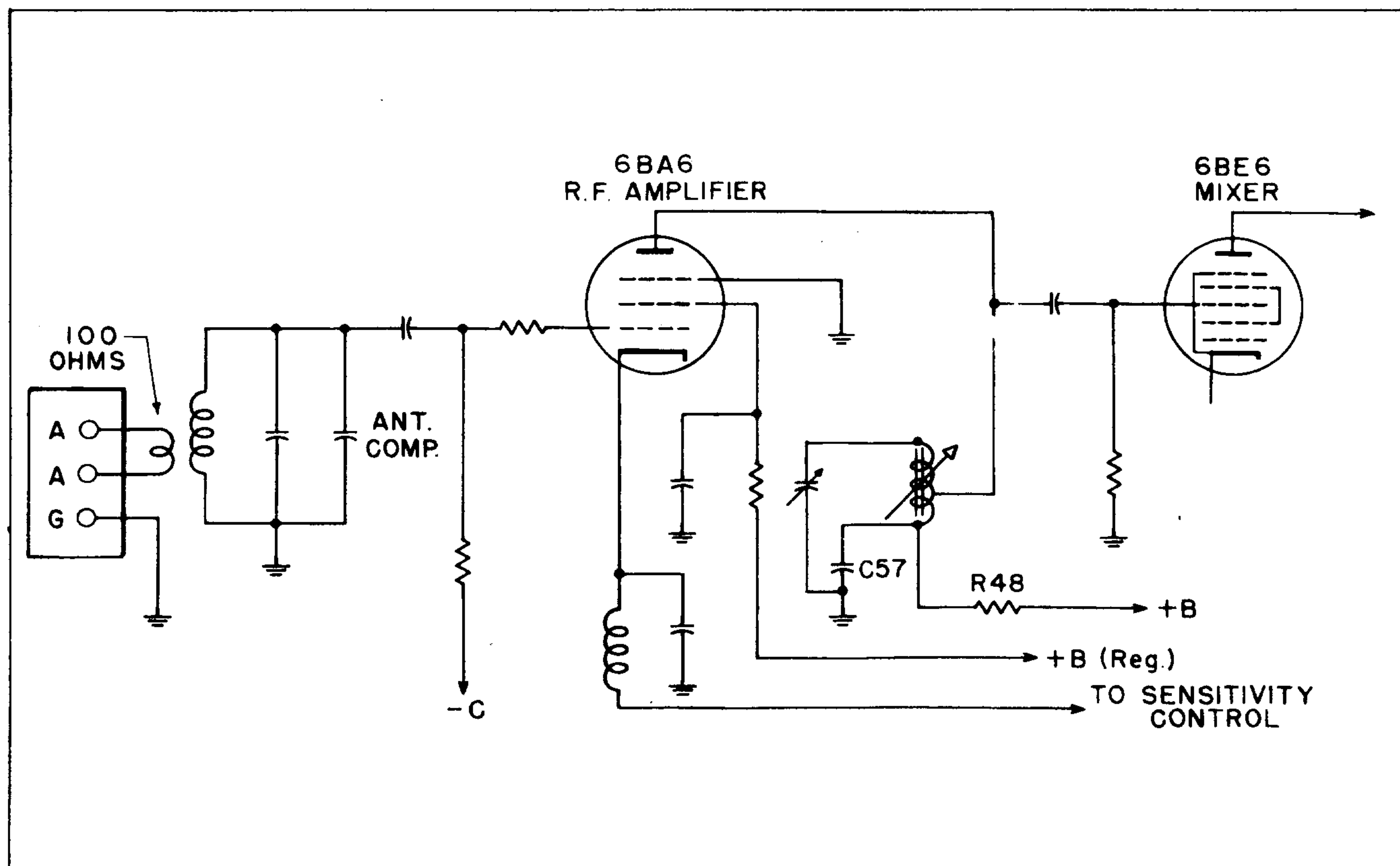

Figure 6. Tuned RF Amplifier and Mixer



CRYSTAL FILTER AND PHASING NETWORK

The patented Hammarlund 455 KCS crystal filter and phasing network is controlled from the HQ-150 front panel. Its six-position SELECTIVITY switch includes an OFF position and five increasingly selective bandwidths.

Switch positions 1, 2, and 3 provide progressively sharper crystal selectivity for use in phone reception. Positions 4 and 5, the sharpest selectivity positions, are recommended for reliable CW or code reception. Highest fidelity is obtained in the OFF position, when the crystal filter is inoperative.

The phasing control may be set to highly attenuate interfering adjacent signals. With experienced operating technique the crystal filter offers distinct advantages under severe interference conditions.

Q MULTIPLIER

The Q Multiplier FREQ control tunes to any frequency within the IF pass band for either acceptance or rejection of any signal in the pass band. With the Q Multiplier Switch in the OFF position, the multiplier is inoperative. With the switch in the PEAK position, the desired signal is tuned and is sharpened and accen-

tuated by the advancement of the PEAK control approaching regeneration. With the switch in the NULL position, an unwanted or interfering signal is tuned and is sharpened and attenuated by advancing the NULL control approaching regeneration. This figure shows the NULL and PEAK curves centered in the regular IF band pass but they may be shifted to any frequency within this band by adjustment of the FREQ control. This makes it possible to use the Q Multiplier in conjunction with the Crystal Filter to obtain two null frequencies, together with a peak frequency, as shown in curve D below. Either of the nulls may be obtained with the Q Multiplier, while the Crystal Filter provides the peak and the other null. In this way a narrow band-pass filter action is obtained.

Various combinations of the setting of the Q Multiplier and Crystal Filter controls will provide a pass band to meet most conditions of operation under adverse circumstances. These possibilities will suggest themselves to the operator as he becomes experienced in their use.

USE OF Q MULTIPLIER

The proper adjustment of the Q Multiplier, or whether to use the Q Multiplier at all, will depend entirely on the use to which the receiver is being put. The short-wave listener should only employ the Q Multiplier or the crystal filter under adverse receiving con-

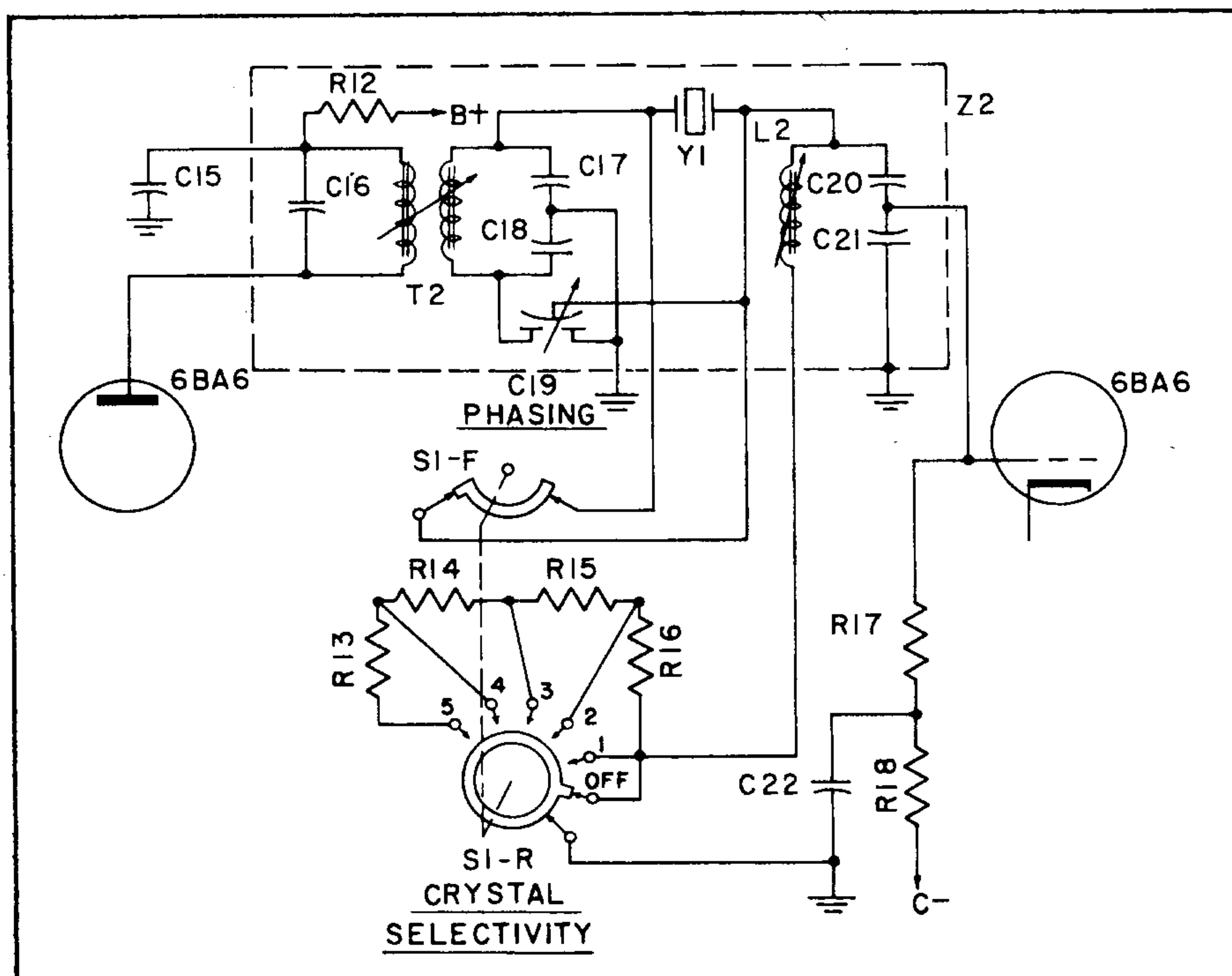

Figure 7. Crystal Filter and Phasing Network



ditions where the use of the crystal filter and/or the Q Multiplier (as the result of the increased selectivity they achieve) may make it possible to eliminate adjacent channel interference.

For example, if two short-wave broadcasting stations are operating on almost the same frequency, the additional selectivity provided by either the crystal filter or the Q Multiplier may make it possible to minimize, if not eliminate entirely, the undesired signal. It is wise to remember however that as a result of increasing the selectivity by narrowing the band width, that the audio quality will suffer. Because of this, the additional selectivity provided by the crystal filter or the Q Multiplier should only be resorted to when interference must be contended with. It is therefore undesirable to use either the crystal filter or the Q Multiplier for standard broadcast band reception unless one desires to hunt for DX B. C. stations and under these circumstances audio quality is a secondary consideration.

For the experienced CW listener, the combination of the Q Multiplier and the crystal filter provides means of rejecting undesired signals that heretofore have not been available. When the Q Multiplier is in the PEAK position, the PEAK control upon being rotated slowly in a clockwise direction will result in increased selectivity, maximum selectivity being just below the point of oscillation. Advancing this control to the point of oscillation will make this apparent by a squeal or howl, and at the same time if the receiver is in the AVC position, the "S" meter may tend to go off scale. Exactly the same action will take place, utilizing the NULL position and usually the maximum NULL position will also be just below the point of oscillation. It will usually be found unnecessary to operate either the PEAK or the NULL controls close to the oscillation point since this is not the most stable operating point. In addition, if these controls are operated too close to the oscillation point, when the frequency control is adjusted, oscillation may occur, necessitating backing down the PEAK or NULL controls, whichever is in use.

It is hardly possible to advise exactly how to adjust the Q Multiplier since each adjustment will depend entirely on existing receiving conditions, and many other variables. Usually, however, the PEAK control should be set at approximately the straight up or 12 o'clock position, and the frequency control is then used to peak the desired signal. If additional peaking is desired, the PEAK control may be advanced very, very slowly and the frequency control again readjusted. The final adjustment will usually be made with the frequency control. The same procedure is employed with the NULL control; however, here you are attempting to adjust the null circuit to reject an undesired signal without seriously affecting the desired signal.

Once the most favorable peak and null settings are found, the respective controls may be left at these

settings. By limiting the control of these functions to the PEAK/NULL switch and the FREQUENCY CONTROL, the operation of the Q Multiplier is greatly simplified. Usually the proper position of the NULL control will be found more critical for maximum rejection than adjustment of the PEAK control. Once the best possible adjustment is obtained in the NULL position, the crystal filter may be brought into play, and additional rejection of the undesired signal obtained by the use of the crystal phasing control.

It must be realized in view of the many variables involved, the procedures indicated herewith must of necessity be of general nature. Actually, experience is the only way one will learn exactly how to take full advantage of the Q Multiplier as well as the crystal filter and its associated phasing control. In view of this, it is highly desirable to spend a few hours in experimenting with the various settings of the controls for a complete understanding of their function in the crowded CW bands as well as for AM and single side-band phone reception.

IF AMPLIFIER

Nine, stable tuned circuits, in three stages of IF amplification (V4, V5, and V6), contribute to sensitivity and selectivity. The gain per stage is purposely low

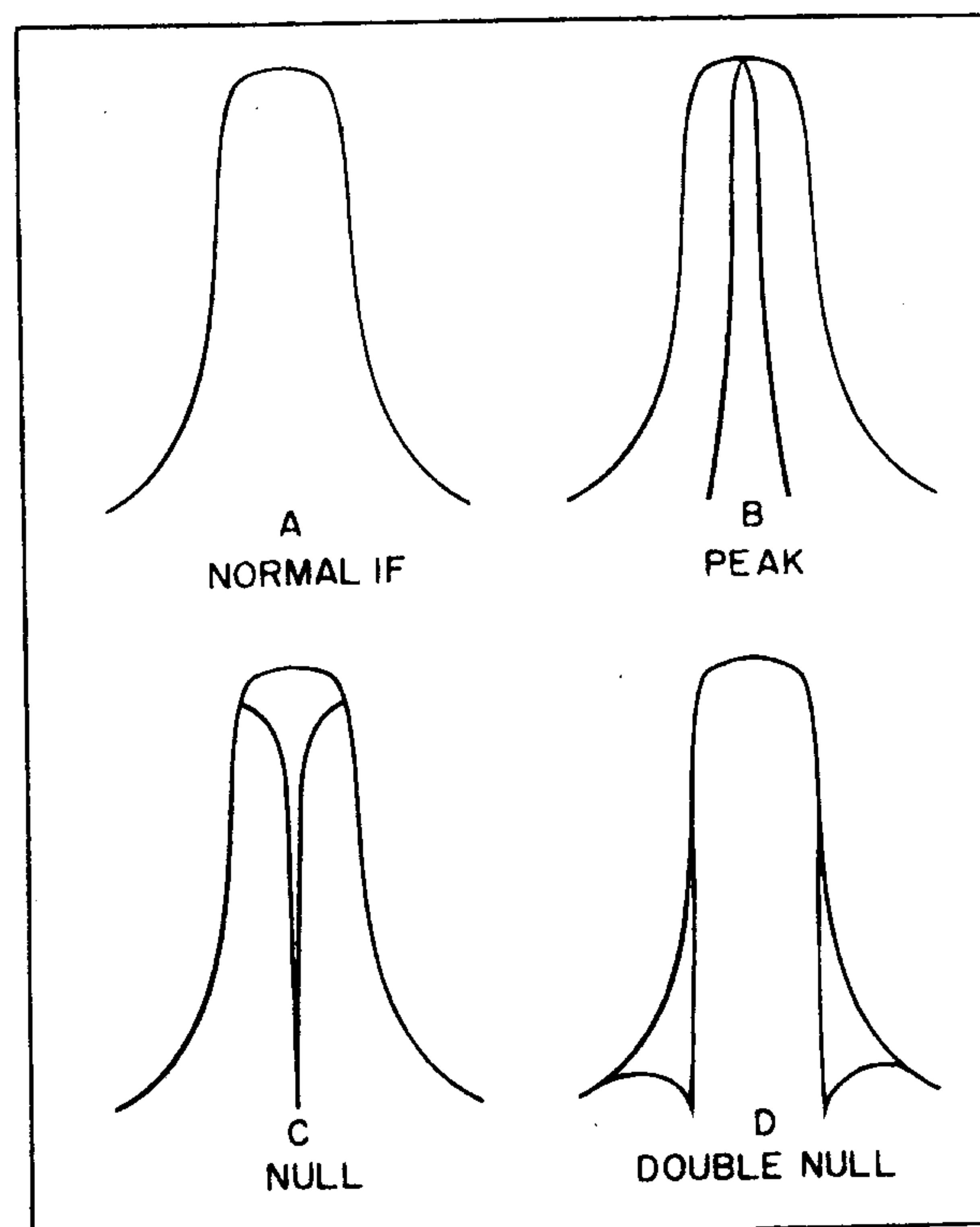

Figure 8. Q Multiplier Representative Curves



in order to maintain stability. Iron core permeability-tuned transformers improve performance and add to the ease of adjustment. The intermediate frequency is 455 KC, the RTMA standard.

AVC SYSTEM

Automatic Volume Control minimizes fading and signal strength variations by controlling the gain of the RF stage V2 and the IF stages V4 and V5. As a result, a comfortable and constant level of audio is maintained.

The Automatic Volume Control is operative only when the MAN-AVC-BFO switch is in the AVC position. With AVC, greatest signal-to-noise ratio will result with the SENSITIVITY control set at maximum. It may be necessary to reduce sensitivity slightly for unusually strong signals.

"S" METER (CARRIER LEVEL)

The "S" or Tuning Meter is provided to assist in tuning and to give an indication of relative signal strength. Because the meter readings are proportional to AVC voltage, it is operative only when the MAN-AVC-BFO switch is in the AVC position.

The meter, which is calibrated to 20 db over S-9, is factory adjusted so that a signal input of approximately 50 microvolts gives a reading of S-9. Each "S" unit indicates a 6 db increase, equivalent to doubling signal strength. Should meter readjustment be necessary:

1. Set front panel SENSITIVITY control to "10" and CRYSTAL SELECTIVITY to "OFF".
2. With receiver off, mechanically zero pointer with a fine screwdriver.
3. With AVC on and the 1st IF tube V4 removed, zero pointer with ZERO ADJ potentiometer R-19.
4. With AVC on and V4 replaced adjust meter sensitivity with SENS potentiometer R-23.

DETECTOR AND NOISE LIMITER

One section of the 6AL5 tube, V7, is used for the second detector and AVC system. This system produces a minimum of distortion.

The other half of V7 operates as a series, self-adjusting noise limiter. It will reduce automobile ignition and other types of impulse noise to a minimum. Intelligibility is not affected by the noise limiter, although it may be switched off if desired. The limiter

only operates efficiently in AVC ON position or MANUAL position but not in BFO position.

BEAT FREQUENCY OSCILLATOR (BFO)

The Beat Frequency Oscillator, which employs one section of the 12AX7 (V8), is designed to provide reception of CW or unmodulated code signals also for reinserted carrier SSB. The CW TONE control permits selection of the desired audio tone. Each calibration division represents approximately 1000 cycles.

The BFO is only operative when the MAN-AVC-BFO switch is in the BFO position.

CRYSTAL CALIBRATOR

The Crystal Calibrator is a highly stable 100 KC crystal oscillator. It is provided with an adjustable trimmer capacitor for accurately adjusting the oscillator frequency against a standard frequency, such as WWV. It provides signal markers at 100 KC intervals throughout the tuning range of the receiver.

AUDIO AMPLIFIER

The first audio stage is a resistance coupled voltage amplifier using the other section of the 12AX7 (V8). The audio output stage, a 6V6GT/G beam power amplifier (V9) provides an undistorted output of at least 2 watts.

The output transformer impedance is 6 ohms to match the voice coil of the Hammarlund or other suitable permanent magnet speaker. The phone jack is connected across the voice coil winding and silences the speaker when the phone plug is inserted.

POWER SUPPLY

The self-contained, stabilized power supply is designed with a large safety factor to insure reliable, trouble-free operation. Humfree performance is provided by a two section filter. The 0C3/VR105 (V10) furnishes regulated voltage to the variable frequency oscillator V1 and the screen grid of V2, V3, V4, and V5.



REALIGNMENT PROCEDURE

IF AMPLIFIER ALIGNMENT

The intermediate-frequency transformers are iron-core permeability-tuned and resonated with fixed silvermica capacitors. A high degree of stability results, which should make IF realignment unnecessary for a long time. Realignment should not be attempted without suitable equipment.

The IF transformers must be tuned for symmetry and proper coincidence of the visible curves as well as for amplitude on the oscilloscope. This requires

a stage-by-stage alignment, starting with the last IF transformer (Z4) and continuing back through the first IF transformer (Z1).

EQUIPMENT REQUIRED

1. Cathode-ray oscilloscope (externally synchronized by the signal generator).
2. Frequency Modulated (swept) signal generator (fairly constant output).
3. Output Meter.

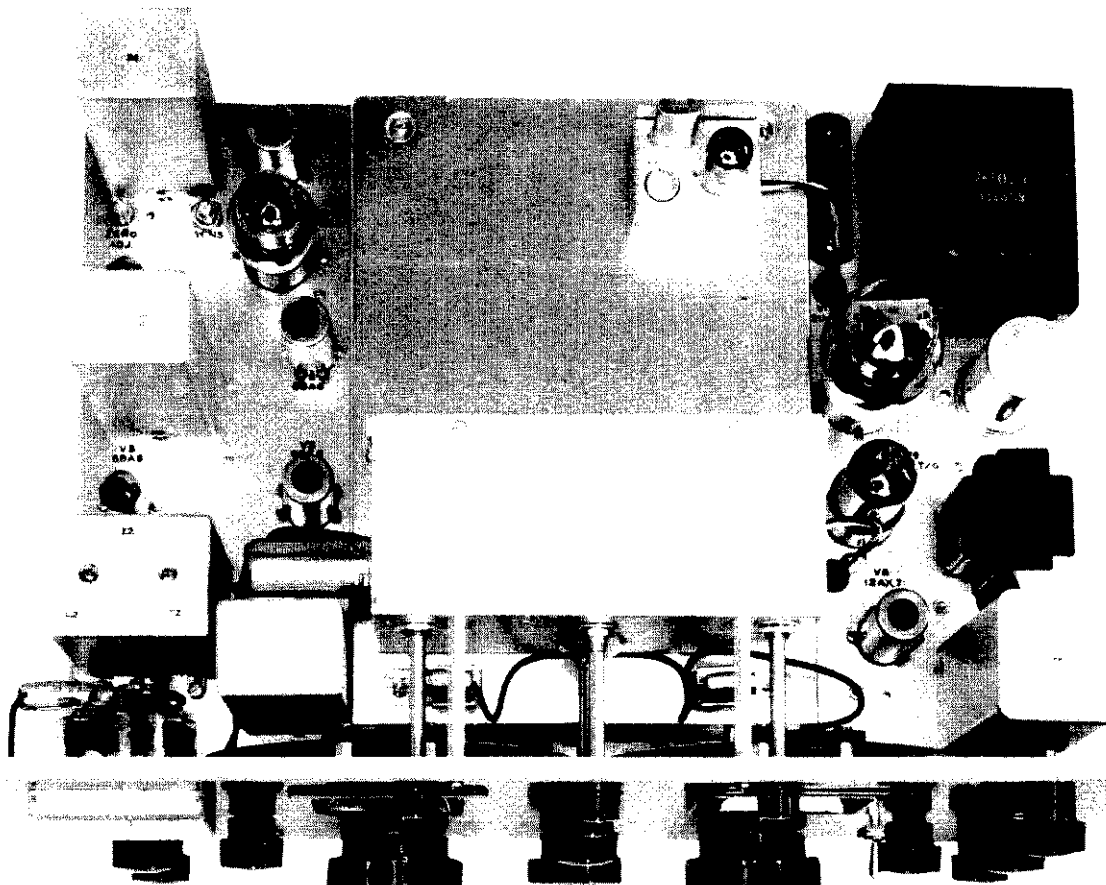

Figure 9. Top View of Chassis



CONTROL SETTINGS

Set receiver controls as follows:

MAIN TUNING DIAL54 MC
Bandswitch (TUNING RANGE)54 - 1.32 MCS
STANDBY-RECEIVE	RECEIVE
LIMITER	OFF
MAN-AVC-BFO	MAN
CRYSTAL SELECTIVITY	OFF

PROCEDURE

Observe the following steps when realigning the IF amplifier stages:

- With generator set at 455 KC apply signal to the grid (pin No. 1) of the 3rd IF tube (V6). Adjust the two inductors of Z4 alternately to obtain **maximum amplitude, symmetry, and pattern coincidence** on the oscilloscope.
- Apply the signal input lead to the grid (pin No. 1) of the 2nd IF tube (V5). Turn the two adjustment screws of Z3 to obtain a symmetrical, coinciding curve with as much amplitude as possible without disturbing the pattern.
- Switch the signal input lead to the grid (pin No. 1) of the 1st IF tube (V4), and adjust the plate inductor (T2) of the crystal filter (Z2) for maximum amplitude at center of curve.
- Apply the signal input to the grid (pin No. 7) of the 6BE6 mixer tube (V3). Adjust screws of 1st IF transformer (Z1) as in (3). This should result in a tall selectivity curve with a slightly flattened peak.
- Turn CRYSTAL SELECTIVITY switch to position No. 1, set CRYSTAL PHASING pointer on arrow, and adjust the grid indicator (L2) of the crystal filter (Z2) for maximum amplitude and symmetry. Adjust signal input or receiver SENSITIVITY control as required to prevent overloading.
- Switch to CRYSTAL SELECTIVITY position No. 2, and if necessary, move PHASING CONTROL slightly from arrow to obtain identical images.

NOTE

Adjust signal generator frequency to obtain coincidence of the images. If complete coincidence is not obtained, alternately make slight adjustments of the PHASING CONTROL and the signal generator frequency, until images coincide. After these last steps have determined the exact frequency of the Quartz crystal, the frequency setting of the signal generator should be left undisturbed.

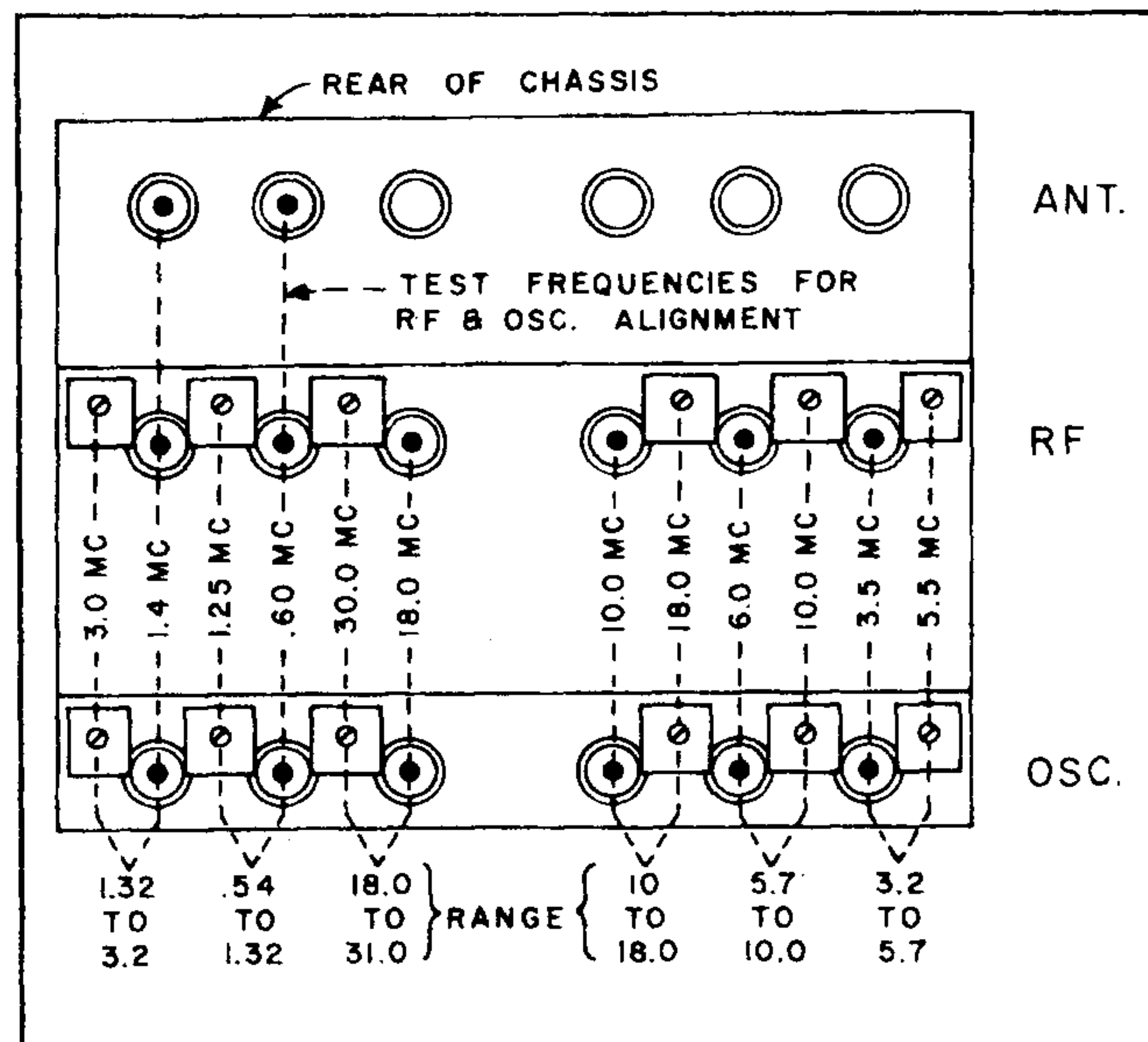

Figure 10. IF Oscillator Tuning Diagram

- Repeat carefully the complete IF alignment procedure (steps 1 through 7) for the crystal frequency.
- The Q Multiplier is adjusted, after the IF alignment is completed, as follows; loosen the nut and bushing assembly in the front panel to permit the frequency shaft to turn without hindrance from the stop pin. Tune the test signal to the IF frequency in the sharp crystal position with the multiplier switch OFF. Switch the multiplier to PEAK and adjust the PEAK control just below oscillation and tune the multiplier FREQ control for maximum amplitude on the scope. Switch to NULL and with the NULL control just below oscillation, observe that a null valley occurs in the scope pattern. Hold the FREQ shaft at the mid frequency position and lock the nut and bushing in the front panel so that the stop pin is at the middle of the frequency range, i. e. pins opposite one another.

RF AMPLIFIER REALIGNMENT

The RF and oscillator stages have been carefully aligned against standard crystals at the factory and are designed to hold their adjustments over a long period of time. Realignment should not be attempted unless it is positive that readjustment is necessary.

As shown on the chart, Figure 10, the front row of adjustments control the H. F. oscillator frequency and consequently dial calibration.



The middle row of adjustments control RF alignment and the rear adjustments are for antenna alignment.

PROCEDURE

CONTROL SETTINGS

Set receiver controls as follows:

STANDBY-RECEIVE	RECEIVE
MAN-AVC-BFO	MAN
CRYSTAL SELECTIVITY	OFF
BAND SPREAD	100
Bandswitch (TUNING RANGE) 54 - 1. 32 MCS
MAIN TUNING 60 MC
Q MULTIPLIER	OFF

Set signal generator controls as follows:

Frequency 60 MC
Modulation	OFF

NOTE

Each band is adjusted for maximum response by changing the inductance at the low-frequency end and the capacitance at the high-frequency end. These adjustments mutually affect each other. If much change is made at one end of the band the other end of the band must also be readjusted. This procedure is repeated until dial calibration coincides with frequency at both ends of the band.

At 30 MCS there is some interaction between the RF and oscillator sections. It is therefore necessary to rock the MAIN TUNING dial back and forth while adjusting the trimmer capacitor, in order to avoid a false setting.

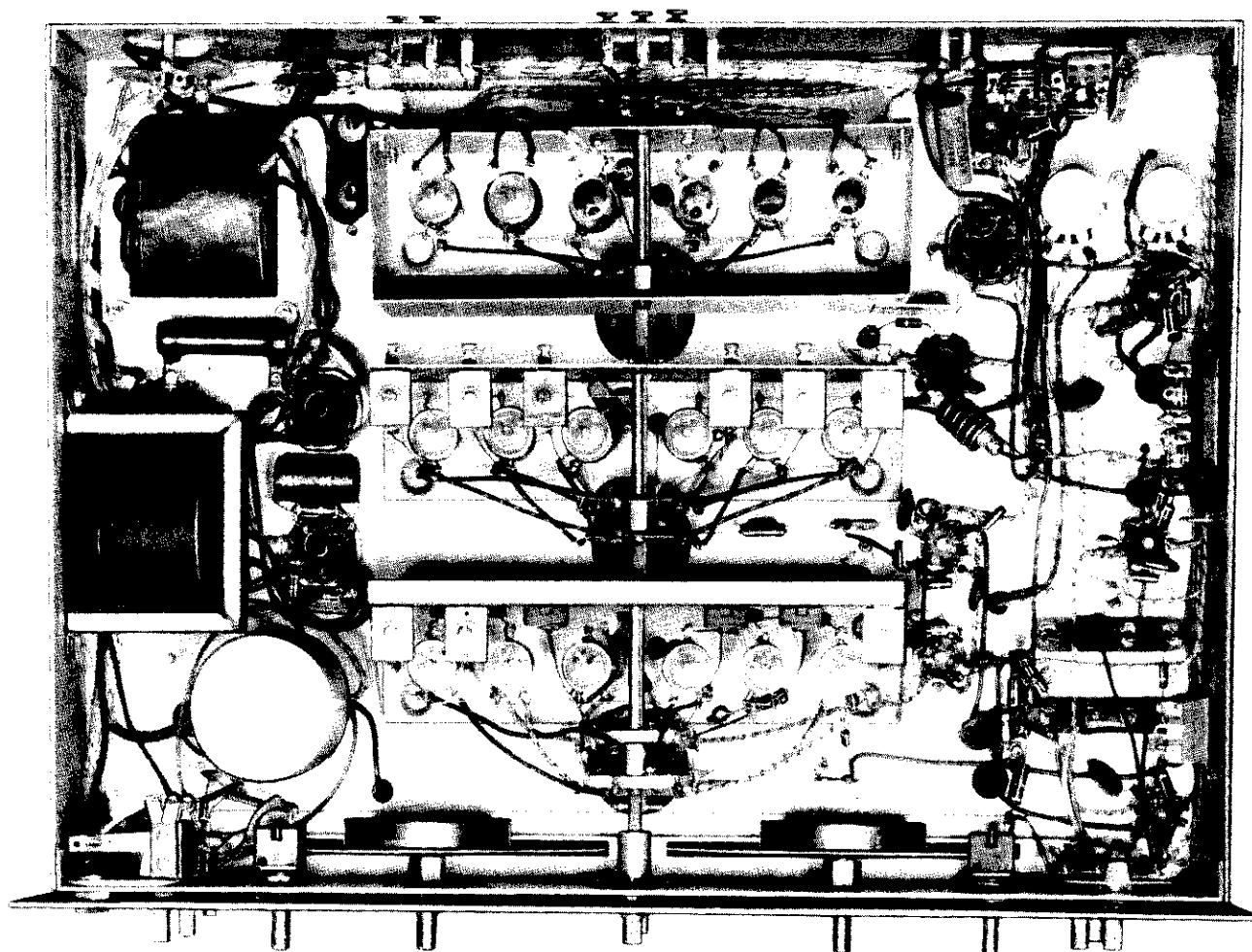

Figure 11. Bottom View of Chassis, Showing Trimmers and Coils



- a. With signal generator connected to the receiver ANTENNA terminals through a series resistor equal to 100 ohms minus the signal generator output impedance, and output meter connected to the SPEAKER terminals, adjust L17 until maximum deflection is obtained on the meter.
- b. Change signal generator frequency to 1.25 MCS as shown in Figure 9. Set MAIN TUNING dial on 1.25 MCS to correspond. Adjust trimmer capacitor C73 to tune in signal, and C69 for maximum response.
- c. Set signal generator to 1.4 MC, change to the 1.32--3.2 MC Band, and set MAIN TUNING dial on 1.4 MC. Adjust L18 until signal appears and L12 and L6 for maximum response.

- d. Change signal generator to 3 MCS, and set MAIN TUNING dial to 3 MCS to correspond. Adjust C64 to tune in signal and C58 for maximum response.

NOTE

This procedure is followed for each band and should be repeated until calibration and tracking are as desired.

- e. Tune in a standard frequency signal, preferably WWV at 5 MCS, tuning for maximum meter reading on AVC. Turn the Calibrator switch to ON and adjust the trimmer capacitor on the Crystal Calibrator for zero beat with the standard signal. Switch to BFO and check for adequate signals of good audible beat frequency output over the upper portion of the 18 to 31 MC range.

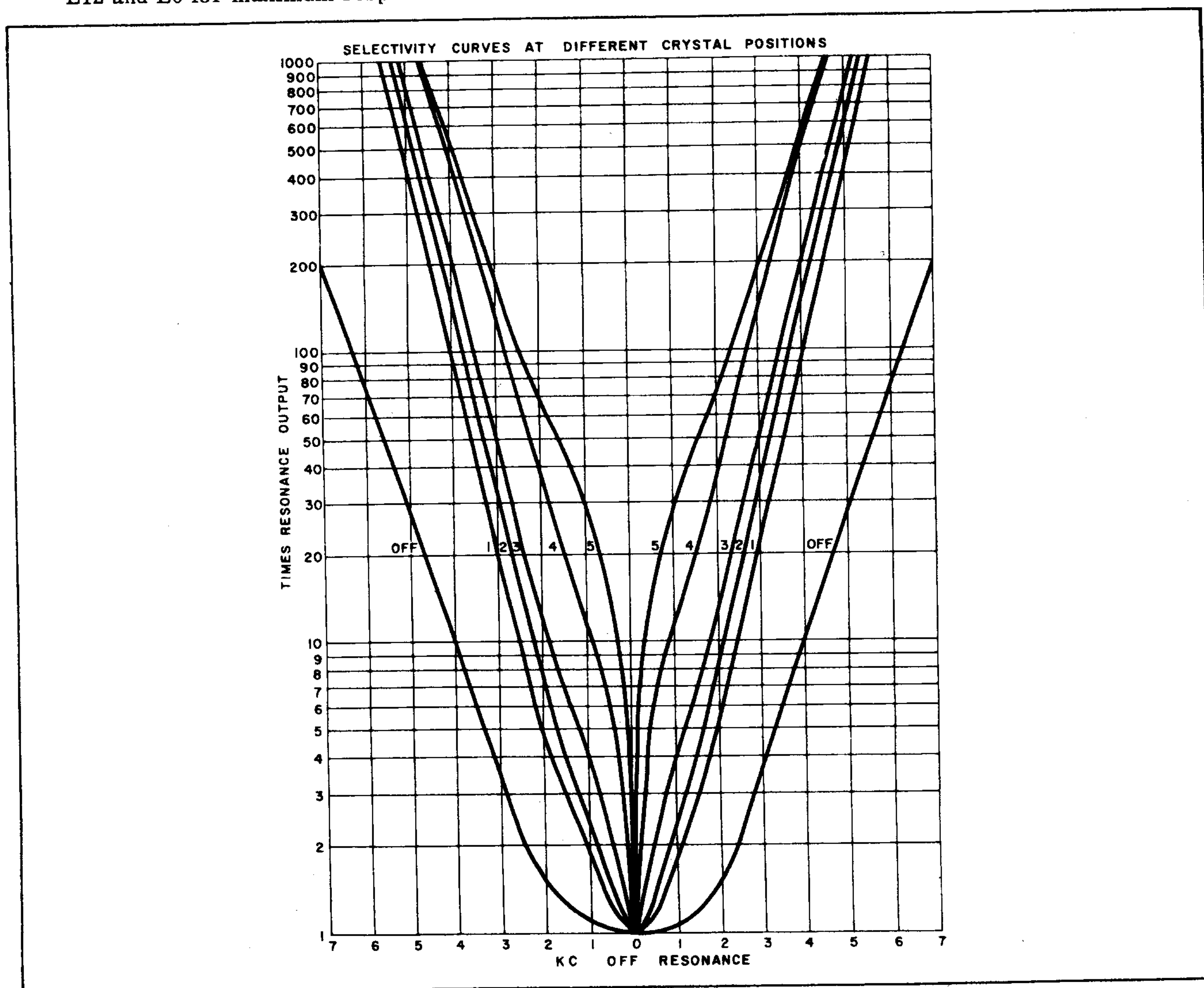

Figure 12. Selectivity Curves



MAINTENANCE

The HQ-150 is designed to give years of trouble-free service without need for repairs. Tube failure is the most common source of trouble. The second most common cause of difficulty is component failure among small resistors and fixed capacitors.

The following charts give voltages and resistances between tube socket terminals and chassis. Voltages indicated are those measured with a vacuum tube voltmeter; resistances with a vacuum tube ohmmeter. Slight variations from voltages indicated may be disregarded.

With the aid of the chart and the schematic diagram, defective components can usually be located. The parts list in the back of this manual gives values and Hammarlund part numbers.

Standard items may be purchased locally. Non-standard components are available on order from the factory.

A sensitive communications receiver should be entrusted only to a qualified technician. Should difficulty be experienced, please write the company for advice or to arrange for factory service.

TUBE SOCKET VOLTAGES TABLE HQ-150

LINE VOLTAGE 117 Vac SENSITIVITY AND AUDIO GAIN CONTROLS MAX. NO SIGNAL, LIMITER OFF, SEND RECEIVE SWITCH ON RECEIVE														
DIAL AT 4.9 mc		MAN-AVC-BFO SWITCH ON MAN. VOLTAGES MEASURED WITH TUBE VOLTMETER										MAN-AVC-BFO SWITCH ON		
Pin No. to Gnd.	RF 6BA6	Mixer 6BE6	Osc 6C4	1st IF 6BA6	2nd IF 6BA6	3rd IF 6BA6	Det Avc 6AL5	Output 6V6/GT	Rect. 5U4GB	Volt. Reg. 0C3/VR105	Calibrator 1/2 6BZ6	Q Multiplier 12AX7 on Min Null	1st Audio 1/2 12AX7	BFO 1/2 12AX7
Pin 1			97				-.38			Tiepoint 215	-30	100	70	
Pin 2		1.35		1.0	1.35	2.45	-.76		310		9.7			
Pin 3	6.2 ac	6.2 ac	6.2 ac	6.2 ac	6.2 ac	6.2 ac	6.2 ac	265		109		.75	.6	
Pin 4								280 ac	280 ac				6.2 ac	
Pin 5	205	212	97	195	210	205				109	90		6.2 ac	
Pin 6	105	96		100	105	125		Tiepoint 215	280 ac		80	220		170
Pin 7	1.25			1.0	3.1	2.45	-.38	6.2 ac			9.7			-15
Pin 8								14.5	310			2.3		
Pin 9											6.2 ac	6.2 ac		

TUBE SOCKET RESISTANCE TABLE HQ-150

POWER PLUG OUT, SENSITIVITY AND AUDIO GAIN CONTROLS MAX. SEND RECEIVE SWITCH ON RECEIVE															MAN-AVC-BFO SWITCH ON-			
MAN-AVC-BFO SWITCH ON MAN										RESISTANCE MEASURED WITH V. T. OHMMETER					MAN			BFO
Pin No. to Gnd.	RF 6BA6	Mixer 6BE6	Osc 6C4	1st IF 6BA6	2nd IF 6BA6	3rd IF 6BA6	Det Avc 6AL5	Output 6V6/GT	Rect. 5U4GB	Volt. Reg. 0C3/VR105	Calibrator 1/2 6BZ6	Q Multiplier 12AX7 on Min Null	1st Audio 1/2 12AX7	BFO 1/2 12AX7				
Pin 1	470K	22K	78K	10K	480K	1.4	242K			Tiepoint 74K	470K	294K	570K					
Pin 2	0	150		130	270	240	550K	0	73K	0	4700	2.2 MEG.	250K					
Pin 3								73K	73K	76K		1500	2200					
Pin 4	0	0	0	0	0	0	0	73K		90	0	0						
Pin 5	74K	74K	78K	74K	74K	74K	0	500K		76K	540K	0						
Pin 6	78K	78K	47K	78K	78K	105K	0	Tiepoint 75K	85		170K	131K		86K				
Pin 7	52	47K	0	30	570	240	242K			76K	4700	2.2 MEG.		33K				
Pin 8								360	73K	74K		6800		0				
Pin 9																		

PARTS LIST HQ-150

Schematic Designation	Description	Hammarlund Part No.
CAPACITORS		
C1, A-F	Main Tuning, variable. (Part of 20840-G1)	
C2, A-I	Band Spread, variable. (Part of 20840-G1)	
C3, 4, 5	Ceramic disc, .02 mf W. V. D. C.	23034-9
C6	Silver mica, 51 mmf 500 W. V. D. C.	23003-87C
C7, 8, 9	Ceramic disc, .02 mf W. V. D. C.	23034-9
C10	Silver mica, 240 mmf 500 W. V. D. C. (Part of Z1, I. F. Transformer Assembly #26121)	23071-56
C11	Silver mica, 260 mmf 500 W. V. D. C. (Part of Z1, I. F. Transformer Assembly #26121)	23003-112
C12, 13, 14, 15	Ceramic disc, .022 mf W. V. D. C.	23034-24
C16	Silver mica, 220 mmf 500 W. V. D. C. (Part of Z2, Crystal Filter Assembly #26125)	23071-55
C17, 18	Silver mica, 100 mmf 500 W. V. D. C. (Part of Z2, Crystal Filter Assembly #26125)	23003-94
C19	Crystal phasing variable, (Part of Z2, Crystal Filter Assembly #26125)	11776-G1
C20	Silver mica 75 mmf 500 W. V. D. C. (Part of Z2, Crystal Filter Assembly #26125)	DM15C750J
C21	Silver mica 3900B mmf 500 W. V. D. C. (Part of Z2, Crystal Filter Assembly #26125)	23015-51
C22, 23, 24	Ceramic disc, .022 mf W. V. D. C.	23034-24
C25	Ceramic, NPO 1.5 mmf 500 W. V. D. C.	23022-2
C26	Silver mica, 240 mmf 500 W. V. D. C. (Part of Z3, I. F. Transformer Assembly #26123)	23071-56
C27	Silver mica, 260 mmf 500 W. V. D. C. (Part of Z3, I. F. Transformer Assembly #26123)	23003-112
C28, 30, 31, 32	Ceramic disc, .02 M. F. D. 600 W. V. D. C.	23034-9
C29	Silver mica 51 mmf 500 V. D. C. W.	23003-87C
C33, 34	Silver mica, 95 mmf 500 W. V. D. C. (Part of Z4, Final I. F. Transformer Assembly #26112)	23071-62
C35, 36	Mica, 100 mmf 500 W. V. D. C.	DM15-C101K
C37	Ceramic disc, .001 mf 600 V. D. C. W.	23034-4
C38	Paper tubular, .02 mf 600 W. V. D. C.	23034-9
C39	Discap .01 mf 1000 W. V. D. C.	23034-8
C40	Ceramic disc, .02 mf W. V. D. C.	23034-9
C41	Silver mica, 170 mmf 500 W. V. D. C.	23006-8
C42	Silver mica, 240 mmf 500 W. V. D. C. (Part of Z5, B. F. O. Assembly #26105)	23071-56
C43	B. F. O. variable, (Part of Z5, B. F. O. Assembly #26105)	11735-G42
C44	Silver mica, 220 mmf 500 W. V. D. C. (Part of Z5, B. F. O. Assembly #26105)	23071-55
C45	Ceramic disc, .01 1000 W. V. D. C. CERAMIC DISC .01 500 W. V. D. C.	23034-8 23034-9
C50	Mica, 620 mmf 500 W. V. D. C. (Part of R. F. Unit Assembly #26131)	23001-141
C52, A, B, C, D	Electrolytic, 10, 500V, 20-450V, 10-50V	15504-70
C53, 54	Ceramic disc, .01 mf.	23034-9
C55	Mica, 620 mmf 500 W. V. D. C.	23001-141
C56	Antenna Compensator, variable (Part of Main Tuning Unit #20840-G1)	SA-617
C57	Mica, 5100 mmf 500 W. V. D. C.	23015-16B
C58, 59, 60	Trimmer, mica 3.35 mmf	16089-2
C61	Trimmer, mica 1.5-9 mmf	16089-1
C62	Trimmer, mica 3.35 mmf	16089-2
C63	Trimmer, mica 1.5-9 mmf	16089-1
C64, 65	Trimmer, mica 3-35 mmf	16089-2
C66, 67	Trimmer, ceramic NPO 1.5-7 mmf	23059-1

PARTS LIST HQ-150 (cont)

Schematic Designation	Description	Hammarlund Part No.
CAPACITORS (Continued)		
C68	Trimmer, ceramic NPO 3-12 mmf	23059-2
C69	Trimmer, mica 1.5-9 mmf	16089-1
C70	Silver mica, 673 mmf 500 W. V. D. C.	23004-2
C71	Silver mica, 300 mmf 500 W. V. D. C.	23003-105
C72	Ceramic disc, .02 W. V. D. C.	23034-9
C73	Mica, 1500 mmf 500 W. V. D. C.	23015-20
C74	Mica, 1000 mmf 500 W. V. D. C.	23015-40
C75, 76	Ceramic disc, .02 mfd 500 V. D. C. W.	23034-9
C77	Trimmer, 8-50 mmf	23038-5
C78	Silver mica, 220 mmf.	DM15C221J
C79	Silver mica, 8 mmf	23034-11
C80, 81	Ceramic disc, .01 mfd	23034-5
C82, 83, 84, 85	Ceramic disc, .005 mfd.	23034-1
C86	Silver mica, 510 mmf	23003-74
C87	Silver mica, 3300 mmf $\pm 5\%$	23011-43
C88	Silver mica, 1100 mmf $\pm 2\%$	23011-59
C89	Silver mica, 5 mmf $\pm 10\%$	23002-1
F1	Fuse, 2 ampere type 3 AG.	15928-7
J1	Phone jack	6087
J2	Relay jack	6142
E1	Antenna terminal strip	6088
E2	Speaker terminal strip	3843
COILS		
L1	R. F. choke 2.5 millihenry	15627-1
L2	Crystal Filter grid coil, (Part of Z2, Crystal Filter Assembly #26125-G1)	31068-G1
L4	Filter choke	26111-1
L5	Antenna Coil Assembly .54 - 1.32 mc range	26051-G1
L6	Antenna Coil Assembly .53 - 3.2 mc range	26051-G3
L7	Antenna Coil 3.2 - 5.7 mc range	6013
L8	Antenna Coil 5.7 - 10 mc range	6016
L9	Antenna Coil 10 - 18 mc range	6019
L10	Antenna Coil 18 - 31 mc range	6022
L11	R. F. Coil Assembly .54 - 1.32 mc range	26204-G2
L12	R. F. Coil Assembly 1.32 - 3.2 mc range	26204-G1
L13	R. F. Coil Assembly 3.2 - 5.7 mc range	26204-G3
L14	R. F. Coil Assembly 5.7 - 10 mc range	26047-G5
L15	R. F. Coil Assembly 10 - 18 mc range	26047-G4
L16	R. F. Coil Assembly 18 - 31 mc range	26047-G3
L17	H. F. Osc. Coil Assembly .54 - 1.32 mc range	26203-G2
L18	H. F. Osc. Coil Assembly 1.32 - 3.2 mc range	26203-G1
L19	H. F. Osc. Coil Assembly 3.2 - 5.7 mc range	26203-G6
L20	H. F. Osc. Coil Assembly 5.7 - 10 mc range	26203-G5
L21	H. F. Osc. Coil Assembly 10 - 18 mc range	26203-G4
L22	H. F. Osc. Coil Assembly 18 - 31 mc range	26203-G3
L23	Q Multiplier Coil Assembly	26215-G1
M1	Carrier Level ("S") meter	26149-3
PL1, 2	Pilot Lamp No. 47, 6.3 V., .15 amp.	16004-1
RESISTORS		
R1	22 Ohms, 1/2 W	19309-9
R2	47,000 Ohms, 1/2 W	19309-89
R3	2,200 Ohms, 1/2 W	19309-57
R4	470,000 Ohms, 1/2 W	19309-113
R5	10,000 Ohms, 1/2 W	19309-73
R6	47,000 Ohms, 1/2 W	19309-89
R7	150 Ohms, 1/2 W	19309-259
R8, 9	2,200 Ohms, 1/2 W	19309-57
R10	10,000 Ohms, 1/2 W	19309-73

PARTS LIST HQ-150 (cont)

Schematic Designation	Description	Hammarlund Part No.
	RESISTORS (Continued)	
R11	2,200 Ohms, 1/2 W	19309-57
R12	2,200 Ohms, 1/2 W (Part of Z2, Crystal Filter Assembly #26125)	19309-57
R13	2,200 Ohms, 1/2 W	19309-57
R14	300 Ohms, 1/2 W	19309-202
R15	51 Ohms, 1/2 W	19309-193
R16	22 Ohms, 1/2 W	19309-9
R17	470,000 Ohms, 1/2 W	19309-113
R18	10,000 Ohms, 1/2 W	19309-73
R19	Potentiometer, 300 Ohms	15368-1
R20	270 Ohms, 1/2 W	19309-262
R21, 22	2,200 Ohms, 1/2 W	19309-57
R23*	Potentiometer, 1,500 Ohms	15368-2
R24*	1,000 Ohms, 1/2 W	19309-49
R25	33,000 Ohms, 1 W	19310-293
R26	47,000 Ohms, 1/2 W (Part of Z4, I. F. Transformer Assembly #26113)	19309-89
R27	2,200 Ohms, 1/2 W	19309-57
R28	240 Ohms, 1/2 W	19309-201
R29	47,000 Ohms, 1/2 W	19309-89
R30, 31	270,000 Ohms, 1/2 W	19309-107
R32	1 Meg Ohms, 1/2 W	19309-121
R33	2.2 Meg Ohms, 1/2 W	19309-129
R34	820,000 Ohms, 1/2 W	19309-119
R35	Resistor 22 Ohms, 1/2 W	19309-9
R36	Potentiometer 250,000 Ohms (switch attached)	6095
R37	2,200 Ohms, 1/2 W	19309-57
R38	62,000 Ohms, 1 W	19310-231
R39	Potentiometer, 10,000 Ohms	26218-4
R40	30 Ohms, 1/2 W	19309-190
R41	33,000 Ohms, 1/2 W (Part of Z5, B. F. O. Assembly #26107)	19309-85
R42	10,000 Ohms, 1/2 W	19309-73
R43	3,900 Ohms, 1/2 W (Part of B. F. O. Bracket Assembly #26029-G2)	19309-63
R46	360 Ohms, 1 W	19310-211
R47	27 Ohms, 1 W	19310-11
R48	2,200 Ohms, 1/2 W (Part of R. F. Unit Assembly #26137)	19309-57
R49	10 Ohms, 1/2 W (Part of H. F. Osc. Assembly #26143)	19309-1
R50	3,000 Ohms, 10 W	19330-6
R51	1,000 Ohms, 15 W	19330-3
R52	2,000 Ohms, 1/2 W (Part of H. F. Osc. Assembly #26143)	19309-57
R55	2,200 Ohms, 1/2 W	19309-81
R56, 57	470 K Ohms, 1/3 W	19317-238
R58	4,700 Ohms, 1/3 W	19317-214
R59	100 K Ohms, 1/3 W	19317-230
R60, 61	2.2 Meg Ohms, 1/2 W	19309-129
R62	220 K Ohms, 1/2 W	19309-105
R63	47 K Ohms, 1/2 W	19309-89
R64	10 K Ohms, 1/2 W	19309-73
R65	1,500 Ohms, 1/2 W	19309-53
R66	6,800 Ohms, 1/2 W	19309-69
R67, 68	Potentiometer 10,000 Ohms	26218-1

PARTS LIST HQ-150 (cont)

Schematic Designation	Description	Hammarlund Part No.
SWITCHES		
S1, F, R,	Crystal Selectivity	
S2	MAN-AVC-BFO	26161-1
S3	Limiter	15864-2
S4	Standby-Receive	15864-2
S5-1F, R	H. F. Osc. plate	6331
S5-2F, R	H. F. Osc. grid	6332
S5-3F, R	Detector grid tap	6064
S5-4F, R	R. F. plate	6063
S5-5F, R	R. F. grid	6063
S5-6F, R	Antenna	6062
S6	Power (Part of R36, Potentiometer #6095)	
S7	Calibrator	6098
S8	Q Multiplier	26217-1
TRANSFORMERS AND IMPEDANCE ASSEMBLIES		
T5	Audio Output Transformer	6086-3
T6	Power Transformer	26109-1
Y1	Crystal, 455 kc	6338-1
Y2	Crystal, 100 kc	38661-1
Z1	1st I. F. Assembly, includes C10, C11, and T1	26121-G1
Z2	Crystal Filter Assembly (2nd I. F.), includes C16, C17, C18, C19, C20, C21, L2, R12, T2, and Y1	26125-G1
Z3	3rd I. F. Assembly, includes C26, C27, and T3	26123-G1
Z4	Final I. F. Assembly, includes C33, C34, R26, and T4	26112-G1
Z5	B. F. O. Assembly, includes C42, C43, C44, L3, and R41.	26105-G1
Z6	Crystal Calibrator Assembly, includes C77, C78, C79, C80, C81, R56, R57, R58, R59 and Y2	38653-G4
Z7	Q Multiplier Assembly, includes C82, C83, C84, C85, C86, C87, C88, L23, R60, R61, R62, R63, R64, R65, R66, R67, R68 and S8	26219-G1
Z8	Audio RC Printed Network	38846-1

*Resistor R24, in some models of the HQ-150, will be a 2.5K Variable Resistor, in substitution for Resistors R23 and R24 as listed here.

NOTE: When ordering replacement parts always specify the serial number, stamped on chassis rear.

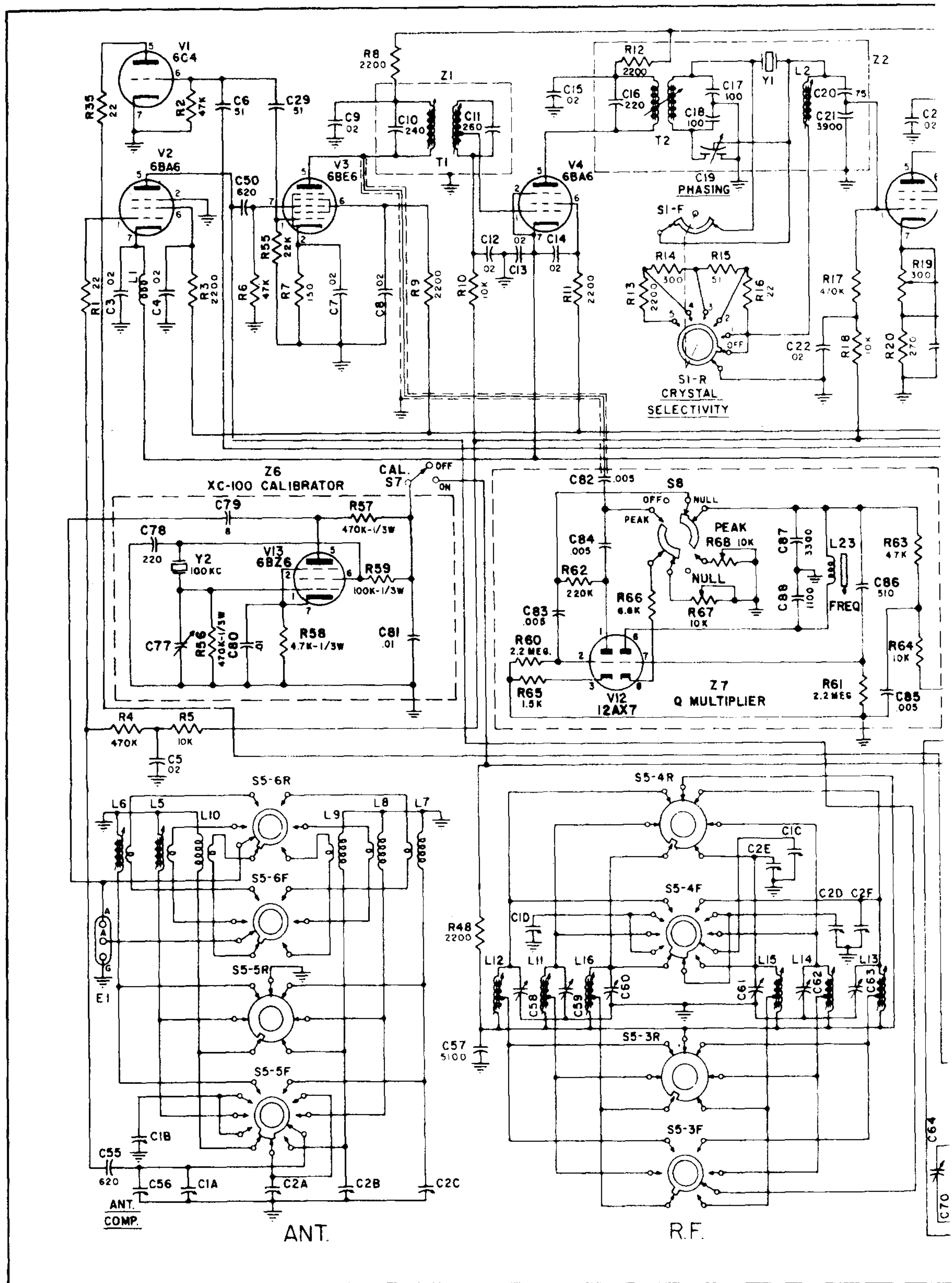

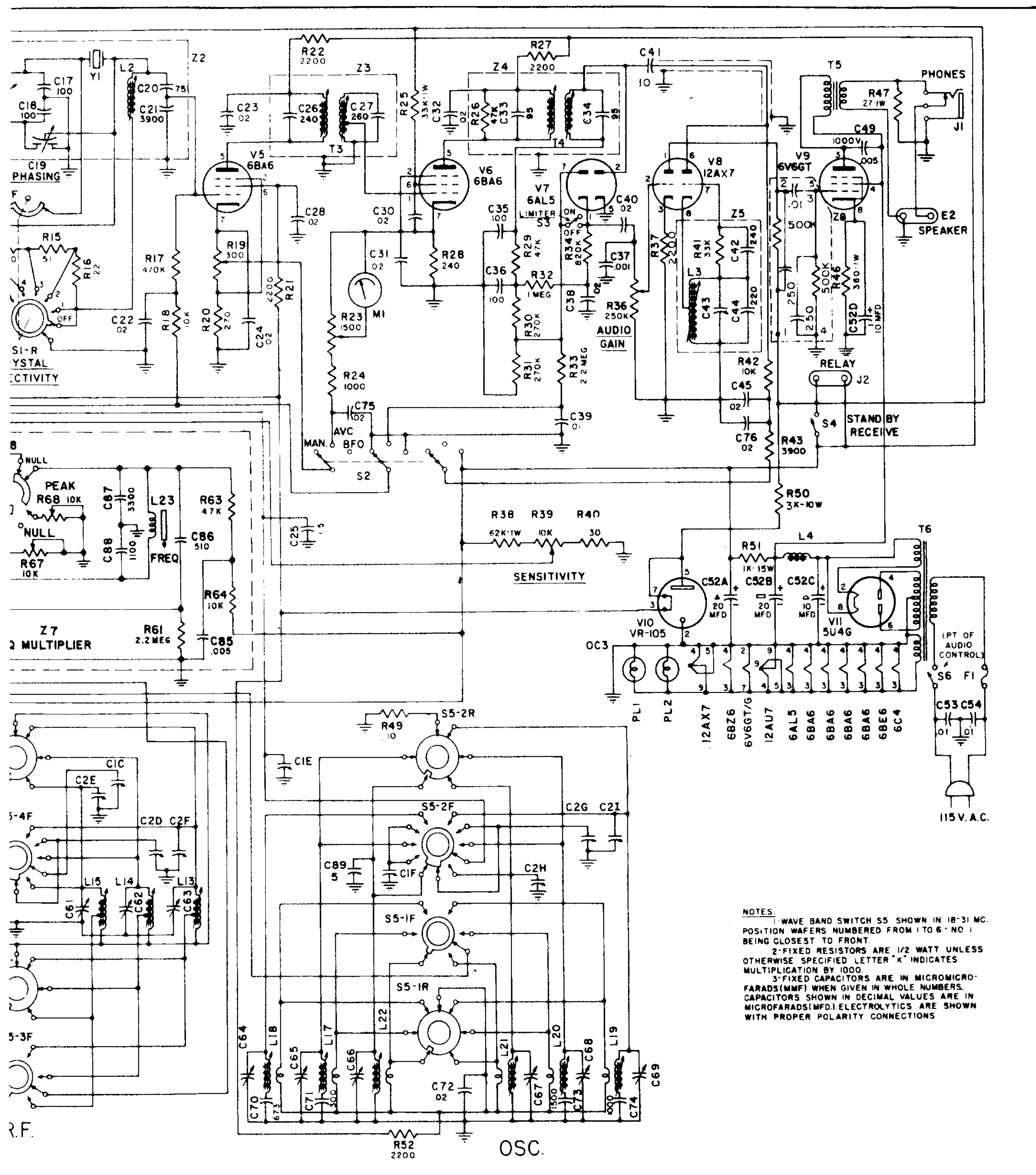

Figure 13. Hammarlund HQ-150 Receiver, Schematic Diagram

K4XL's **BAMA**

This manual is provided **FREE OF CHARGE** from the “BoatAnchor Manual Archive” as a service to the Boatanchor community.

It was uploaded by someone who wanted to help you repair and maintain your equipment.

If you paid anyone other than BAMA for this manual, you paid someone who is making a profit from the free labor of others without asking their permission.

You may pass on copies of this manual to anyone who needs it. But do it without charge.

Thousands of files are available without charge from BAMA. Visit us at <http://bama.sbc.edu>